



ACCUMULATION SCRAY

A complete range of devices for carrying out processes in the finishing stages.



ACCUMULATION SCRAY

Fabric accumulation machine, to avoid line stops during roll change.

| | |
|-------------------------------------|--|
| overall dimensions L x H x W | 2020 x 2060 x (RW+700) weight 1400kg |
| material | carbon steel / stainless steel optional |
| color on painted steel | RAL 7021 for the structure RAL 9006 for side doors |
| rollers width | from 2000 mm to 4000 mm |
| fabric width | from 1800 mm to 3800 mm |
| installation | on wheels or floor fixing |
| mechanical speed max | 120 m/min |
| voltage | standard 3x400VAC-50Hz or others on request |
| installed power | 3,5 kW |
| motorization | AC controlled by inverter |
| ambient temperature | from 0° to + 55 ° |
| noise | <75 dB(A) |
| operator pannel | color touch screen |
| teleservice | optional |
| control | PLC |
| industry 4.0 | optional |



www.bianco-spa.com

ACCUMULATION SCRAY

A complete range of devices for carrying out processes in the finishing stages.

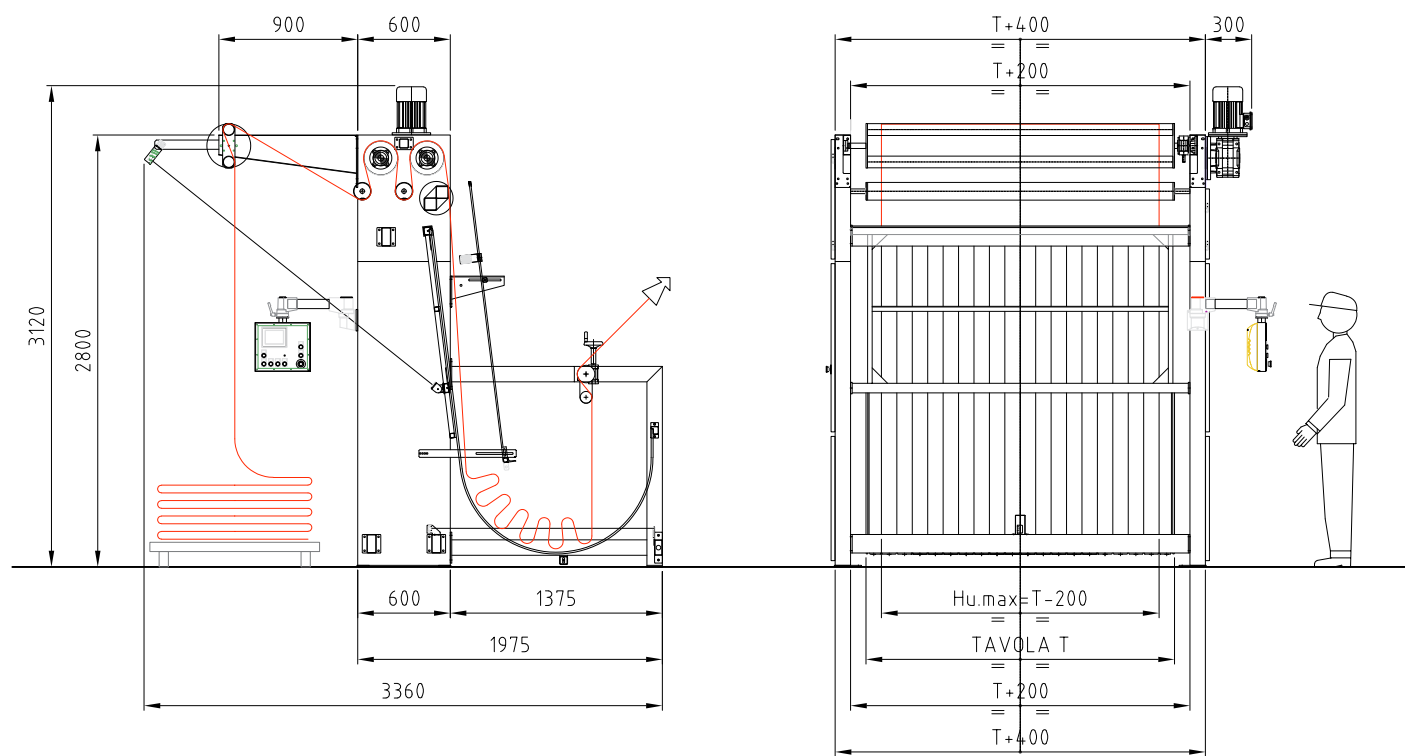

OPTIONALS

- inlet Centring Unit
- compensator (dancing roller) in case of axial unwinding for speed sincronization
- speed Compensating Cylinder at exit
- tensioning Brake at Accumulation Scray exit
- anti-static bars
- stock check